

<b>International Association Of Certified Practicing Engineers</b>	 <b>www.iacpe.com</b> Knowledge, Certification, Networking	Page : 1 of 107
		Rev: 01  Rev. 01 – Jan 2016
<b>IACPE</b> No 19, Jalan Bilal Mahmood 80100 Johor Bahru Malaysia	<b>ELECTRICAL POWER SUPPLY AND REGULATION</b>  <b>LEVEL TWO CPE TRAINING MODULE</b>	

The International Association of Certified Practicing Engineers is providing the introduction to the Training Module for your review.

We believe you should consider joining our Association and becoming a Certified Practicing Engineer. This would be a great option for engineering improvement, certification and networking.

This would help your career by

1. Providing a standard of professional competence in the practicing engineering and management field
2. Identify and recognize those individuals who, by studying and passing an examination, meets the standards of the organization
3. Encourage practicing engineers and management professionals to participate in a continuing program of personal and professional development

[www.IACPE.com](http://www.IACPE.com)

<b>International Association Of Certified Practicing Engineers</b>	<b>ELECTRICAL POWER SUPPLY AND REGULATION</b>  <b>CPE LEVEL TWO TRAINING MODULE</b>	Page 2 of 107
		Rev: 01
		JAN 2016

## TABLE OF CONTENT

### INTRODUCTION

Scope	8
General Consideration	9
<b>DEFINITION</b>	<b>23</b>
<b>NOMENCLEATURE</b>	<b>25</b>
Greek Letters	26

### THEORY

<b>I. TRANSFORMERS</b>	
a) Electromagnetic Transformers	28
b) The Ideal Transformers	32
c) Principles of Operation	38
d) Testing to Determine Transformer Parameters	39
e) Efficiency of a Transformer	41
f) Regulation of a Transformer	41
g) Application	42
 <b>II. RECTIFIER AND FILTER CIRCUIT</b>	
a) Rectifier Circuit	45
b) Filter Circuit	53
 <b>III. SWITCHING POWER SUPPLIES</b>	
a) Linear Regulator Versus Switching Power Supplies	56

<b>International Association Of Certified Practicing Engineers</b>	<b>ELECTRICAL POWER SUPPLY AND REGULATION</b>	Page 3 of 107
		Rev: 01
		JAN 2016

b) The Buck Regulator	58
c) The Boost Regulator	62
d) The Buck / Boost Regulator	66
e) The Fly back Regulator	70
f) The Half – Forward Regulator	74
g) The Push – Pull Regulator	77
h) The Full – Bridge Regulator	82
i) The Half – Bridge Regulator	86
<b>IV. VOLTAGE REGULATION</b>	
a) Types of Voltage Regulation	91
b) Selecting a Voltage Regulator	92
c) Two Discrete Voltage Examples	93
d) IC Regulator Example	96
e) Voltage Regulator Packaging and Heat Sinking	102

## REFERENCES

## LIST OF TABLE

Table 1	: Case to Heat Sink Thermal Resistance, $\theta_{cs}$ , for various Packages and Mounting Arrangements	105
Table 2	: Commercial Heat Sink Selection Guide	105

## LIST OF FIGURE

Figure 1	: PWM Converter Methods : (a) direct duty cycle, (b) voltage feedforward control, (c) current mode control	11
----------	--	----

<b>International Association Of Certified Practicing Engineers</b>	<b>ELECTRICAL POWER SUPPLY AND REGULATION</b>	Page 4 of 107
		Rev: 01
	<b>CPE LEVEL TWO TRAINING MODULE</b>	JAN 2016

<b>Figure 2</b>	<b>: Non – Isolated Cuk Converter</b>	<b>12</b>
<b>Figure 3</b>	<b>: (a) Flyback converter. The clamp winding shown is optimal and is used to clamp the transistor voltage stress to <math>V_{in} + nV_o</math>. (b) Flyback converter waveforms without the clamp winding. The leakage inductance spikes vanish with the clamp winding.</b>	<b>13</b>
<b>Figure 4</b>	<b>: (a) Forward converter. The clamp winding shown is required for operation. (b) Forward converter waveforms.</b>	<b>14</b>
<b>Figure 5</b>	<b>: (a) Two – transistor single-ended fly back converter (b) Two – transistor single – ended forward converter</b>	<b>15</b>
<b>Figure 6</b>	<b>: Sepic Converter</b>	<b>15</b>
<b>Figure 7</b>	<b>: (a) Push – pull converter and (b) its opening waveforms</b>	<b>16</b>
<b>Figure 8</b>	<b>: Half – bridge converter. Coupling capacitor <math>C_c</math>, is used to avoid transformer saturation.</b>	<b>17</b>
<b>Figure 9</b>	<b>: Full – Bridge Converter</b>	<b>17</b>
<b>Figure 10</b>	<b>: (a) Zero – current resonant switch : (i) L – type and (ii) M – Type. (b) Half wave configuration using L – Type ZC resonant switch. (c) Full – wave configuration using L – Type ZC resonant switch</b>	<b>19</b>
<b>Figure 11</b>	<b>: (a) Zero – voltage resonant switches. (b) Half – wave Configuration Using ZV resonant switch shown in Figure 10 (a)(i). (c) Full – wave configuration using ZV resonant switch shown in Figure 10 (a)(i).</b>	<b>19</b>
<b>Figure 12</b>	<b>: (a) Implementation of ZCS QR buck converter using L – Type resonant switch. (b) Operating waveforms for half – wave mode. (c) Operating waveforms for full – wave mode.</b>	<b>20</b>
<b>Figure 13</b>	<b>: (a) Implementation of ZVS QR boost converter using resonant</b>	

<b>International Association Of Certified Practicing Engineers</b>	<b>ELECTRICAL POWER SUPPLY AND REGULATION</b>	<b>Page 5 of 107</b>
		<b>Rev: 01</b>
	<b>CPE LEVEL TWO TRAINING MODULE</b>	<b>JAN 2016</b>

	switch shown in Figure 11 (a) (i). (b) Opening waveforms for half-wave mode(c) Operating waveforms for full-wave mode.	21
<b>Figure 14</b>	<b>: High-frequency resonant converter (half-bridge version) configurations suitable for operation above resonance. <math>C_{n1}</math> and <math>C_{n2}</math> are the snubber capacitors. (a) Series resonant converter. Leakage inductances of the HF transformer can be part of resonant inductance. (b)Parallel resonant converter. (c)Series-parallel (or LCC-type) resonant converter with capacitor <math>C_t</math> placed on the secondary side of the HF transformer.</b>	<b>22</b>
<b>Figure 15</b>	<b>: Flux paths in the core and windings of an iron cored transformer</b>	<b>27</b>
<b>Figure 16</b>	<b>: Linked Coils</b>	<b>29</b>
<b>Figure 17</b>	<b>: Dotted schematic symbol for a transformer</b>	<b>32</b>
<b>Figure 18</b>	<b>: Equivalent Circuit</b>	<b>33</b>
<b>Figure 19</b>	<b>: Low – frequency Equivalent Circuit</b>	<b>35</b>
<b>Figure 20</b>	<b>: Midband Equivalent Circuit</b>	<b>36</b>
<b>Figure 21</b>	<b>: High – Frequency Model</b>	<b>37</b>
<b>Figure 22</b>	<b>: Ultra – High – Frequency Model</b>	<b>38</b>
<b>Figure 23</b>	<b>: Connection for Open – Circuit Test</b>	<b>39</b>
<b>Figure 24</b>	<b>: Short – Circuit Test Setup</b>	<b>40</b>
<b>Figure 25</b>	<b>: (a) Equivalent for 1:1, (b) Equivalent for step-up (<math>n &gt; 1.0</math>), (c) equivalent for step down (<math>n &lt; 1.0</math>)</b>	<b>44</b>
<b>Figure 26</b>	<b>: Pulse Terminology</b>	<b>45</b>
<b>Figure 27</b>	<b>: Half – Wave Rectifier : (a) Circuit Diagram, Input and Output Waveforms</b>	<b>46</b>
<b>Figure 28</b>	<b>: Full wave rectifier : (a) Schematic diagram, (b) Input and Output Waveforms</b>	<b>48</b>

<b>International Association Of Certified Practicing Engineers</b>	<b>ELECTRICAL POWER SUPPLY AND REGULATION</b>	<b>Page 6 of 107</b>
		<b>Rev: 01</b>
	<b>CPE LEVEL TWO TRAINING MODULE</b>	<b>JAN 2016</b>

<b>Figure 29 : Bridge rectifier : (a) Circuit Schematic, (b) Input and Output voltage waveforms</b>	<b>49</b>
<b>Figure 30 : Voltage doubler circuit : (a) diagram, (b) voltage across diode D<sub>1</sub></b>	<b>50</b>
<b>Figure 31 : A precision rectifier : (a) Circuit diagram, (b) an improved Version of the precision half-wave rectifier</b>	<b>51</b>
<b>Figure 32 : Precision full wave rectifier with a diode placed in the feedback loop</b>	<b>52</b>
<b>Figure 33 : A Precision bridge rectifier</b>	<b>53</b>
<b>Figure 34 : Half-wave and RC filter circuit : (a) schematic diagram, (b) input and output waveforms</b>	<b>53</b>
<b>Figure 35 : Filter Circuits : (a) full wave rectifier with L-section filter, (b) multiple L-section filter</b>	<b>55</b>
<b>Figure 36 : The Buck Regulator Topology</b>	<b>58</b>
<b>Figure 37 : DC Waveforms for a buck regulator</b>	<b>59</b>
<b>Figure 38 : AC Waveforms for a buck regulator</b>	<b>60</b>
<b>Figure 39 : The boost regulator topology</b>	<b>63</b>
<b>Figure 40 : DC waveform for a boost regulator</b>	<b>63</b>
<b>Figure 41 : The buck/boost regulator topology</b>	<b>65</b>
<b>Figure 42 : The buck/boost regulator topology</b>	<b>66</b>
<b>Figure 43 : DC waveform for a buck/boost regulator</b>	<b>67</b>
<b>Figure 44 : AC waveforms for a buck/boost regulator</b>	<b>68</b>
<b>Figure 45 : Flyback regulator topology</b>	<b>70</b>
<b>Figure 46 : DC waveforms for a fly back regulator</b>	<b>71</b>
<b>Figure 47 : AC waveforms for a playback regulator</b>	<b>72</b>
<b>Figure 48 : The Half – forward regulator topology</b>	<b>74</b>
<b>Figure 49 : DC waveforms for a half – forward regulator</b>	<b>75</b>

<b>International Association Of Certified Practicing Engineers</b>	<b>ELECTRICAL POWER SUPPLY AND REGULATION</b>	Page 7 of 107
		Rev: 01
		JAN 2016

<b>Figure 50 : AC waveform for a half – forward regulator</b>	<b>75</b>
<b>Figure 51 : The push – Pull Regulator Topology</b>	<b>77</b>
<b>Figure 52 : DC waveforms for a push – pull regulator</b>	<b>78</b>
<b>Figure 53 : AC Waveforms for a push-pull regulator</b>	<b>80</b>
<b>Figure 54 : The Full – Bridge Regulator Topology</b>	<b>82</b>
<b>Figure 55 : DC Waveforms for a full – bridge regulator</b>	<b>79</b>
<b>Figure 56 : AC waveforms for a full – bridge regulator</b>	<b>84</b>
<b>Figure 57 : The half – bridge regulator topology</b>	<b>86</b>
<b>Figure 58 : DC waveforms for a half-bridge regulator</b>	<b>87</b>
<b>Figure 59 : AC Waveforms for a half–bridge regulator</b>	<b>87</b>
<b>Figure 60 : A typical power supply</b>	<b>90</b>
<b>Figure 61 : Voltage regulator groupings</b>	<b>91</b>
<b>Figure 62 : Simple Zener Regulator</b>	<b>92</b>
<b>Figure 63 : An op amp voltage regulator</b>	<b>93</b>
<b>Figure 64 : A Discrete voltage regulator</b>	<b>95</b>
<b>Figure 65 : A Voltage regulator with current limiting</b>	<b>96</b>
<b>Figure 66 : Configuration for an adjustable output three- terminal regulator</b>	<b>97</b>
<b>Figure 67 : D/A Controlled Voltage Regulator</b>	<b>98</b>
<b>Figure 68 : A three-terminal IC regulator with current boosting</b>	<b>99</b>
<b>Figure 69 : Current limiting schemes : (a) Simple current limiting, (b) foldback current limiting</b>	<b>100</b>
<b>Figure 70 : A 723 voltage regulator configured for foldback current limiting</b>	<b>101</b>
<b>Figure 71 : Contributors to thermal resistance</b>	<b>102</b>
<b>Figure 72 : Available regulator package styles</b>	<b>103</b>

<b>International Association Of Certified Practicing Engineers</b>	<b>ELECTRICAL POWER SUPPLY AND REGULATION</b>  <b>CPE LEVEL TWO TRAINING MODULE</b>	<b>Page 8 of 107</b>
		<b>Rev: 01</b>
		<b>JAN 2016</b>

## **INTRODUCTION**

### **Scope**

A power supply is an electronic device that supplies electric energy to an electrical load. The primary function of a power supply is to convert one form of electrical energy to another, as a result, power supplies are sometimes referred to as electric power converters. Some power supplies are discrete, stand alone devices, whereas others are built into larger devices along with their loads.

Depending on its design, a power supply may obtain energy from various types of energy sources, including electrical energy transmission systems, energy storage devices such as a batteries and fuel cells, electro mechanical systems such as generators and alternators, solar power converters, or another power supply.

This training module provides an overview electrical power supply and regulation with the basic laws of electrical power supply, switching of power supply, and applications.



<b>International Association Of Certified Practicing Engineers</b>	<b>ELECTRICAL POWER SUPPLY AND REGULATION</b>	<b>Page 9 of 107</b>
		<b>Rev: 01</b>
	<b>CPE LEVEL TWO TRAINING MODULE</b>	<b>JAN 2016</b>

## **General Consideration**

### **Power Supplies**

Power supplies are used in many industrial and aerospace applications and in consumer products. Some of the requirements of power supplies are small size, light weight, low cost, and high power conversion efficiency. In addition to these, some power supplies require the following:

- electrical isolation between the source and load,
- low harmonic distortion for the input and output waveforms,
- and high power factor (PF) if the source is ac voltage.

Some special power supplies require controlled direction of power flow.

Basically two types of power supplies are required: direct current (DC) power supplies and alternating current (AC) power supplies. The input to these power supplies can be ac or dc.

### **DC Power Supplies**

If an ac source is used electrical isolation can only be provided by bulky line frequency transformers. The ac source can be rectified with a diode rectifier to get an uncontrolled dc, and then a dc-to-dc converter can be used to get a controlled dc output. Electrical isolation between the input source and the output load can be provided in the dc-to-dc converter using a high-frequency (HF) transformer. Such HF transformers have small size, light weight, and low cost compared to bulky line frequency transformers. Whether the input source is dc or ac, dc-to-dc converters form an important part of dc power supplies. DC power supplies can be broadly classified as linear and switching power supplies.

A linear power supply is the oldest and simplest type of power supply. The output voltage is regulated by dropping the extra input voltage across a series transistor (therefore, also referred to as a series regulator). They have very small output ripple, theoretically zero noise, large hold-up time (typically 1–2 ms), and fast response. Linear power supplies have the following disadvantages: very low efficiency, electrical isolation can only be on 60-Hz ac side, larger volume and weight, and, in general, only a single output possible. However, they are still used in very small regulated power supplies and in some special applications. Three terminal linear regulator integrated circuits (ICs) are readily available, are easy to use, and have built-in load short-circuit protection.

<b>International Association Of Certified Practicing Engineers</b>	<b>ELECTRICAL POWER SUPPLY AND REGULATION</b>	<b>Page 10 of 107</b>
		<b>Rev: 01</b>
	<b>CPE LEVEL TWO TRAINING MODULE</b>	<b>JAN 2016</b>

Switching power supplies use power semiconductor switches in the on and off switching states, resulting in high efficiency, small size, and light weight. With the availability of fast switching devices, HF magnetics and capacitors, and high-speed control ICs, switching power supplies have become very popular. They can be further classified as pulse width-modulated (PWM) converters and resonant converters.

### **Pulse width – Modulated Converters**

These converters employ square-wave pulse width modulation to achieve voltage regulation. The average output voltage is varied by varying the duty cycle of the power semiconductor switch. The voltage waveform across the switch and at the output are square wave in nature (refer to Figure 1 (b)) and they generally result in higher switching losses when the switching frequency is increased. Also, the switching stresses are high with the generation of large electromagnetic interference (EMI), which is difficult to filter. However, these converters are easy to control, well understood, and have wide load control range. The methods of control of PWM converters are discussed next.

### **The Methods of Control**

The PWM converters operate with a fixed-frequency, variable duty cycle. Depending on the duty cycle, they can operate in either Continuous Current Mode (CCM) or discontinuous current mode (DCM). The three possible control methods [Severns and Bloom, 1988; Hnatek, 1981; Unitrode Corporation, 1984; Motorola, 1989; Philips Semiconductors, 1991] are briefly explained below.

1. Direct duty cycle control is the simplest control method. A fixed-frequency ramp is compared with the control voltage (Figure 1 (a)) to obtain a variable duty cycle base drive signal for the transistor. This is the simplest method of control. Disadvantages of this method are:
  - a) Provides no voltage feedforward to anticipate the effects of input voltage changes, slow response to sudden input changes, poor audio susceptibility, poor open-loop line regulation, requiring higher loop gain to achieve specifications.
  - b) Poor dynamic response.

2. Voltage feedforward control. In this case the ramp amplitude varies in direct proportion to the input voltage (Figure 1 (b)). The open-loop regulation is very good.
  
3. Current mode control. In this method, a second inner control loop compares the peak inductor current with the control voltage which provides improved open-loop line regulation (Figure 1 (c)). All the problems of the direct duty cycle control method 1 above are corrected with this method. An additional advantage of this method is that the two-pole second-order filter is reduced to a single-pole (the filter capacitor) first-order filter, resulting in simpler compensation networks.

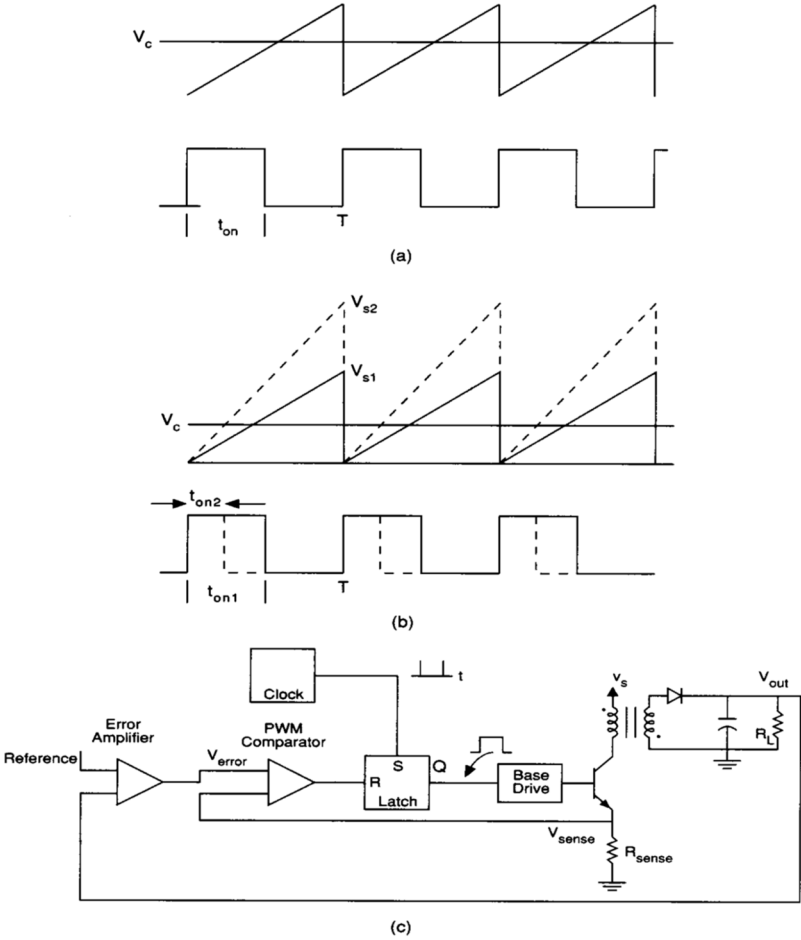

Figure 1: PWM Converter Methods: (a) direct duty cycle, (b) voltage feedforward control, (c) current mode control

<b>International Association Of Certified Practicing Engineers</b>	<b>ELECTRICAL POWER SUPPLY AND REGULATION</b>	<b>Page 12 of 107</b>
	<b>CPE LEVEL TWO TRAINING MODULE</b>	<b>Rev: 01</b>
		<b>JAN 2016</b>

PWM converters can be classified as single-ended and double-ended converters. These converters may or may not have a high-frequency transformer for isolation.

### No isolated Single – Ended PWM Converters.

The basic nonisolated single-ended converters are: (a) buck (step-down), (b) boost (step-up), (c) buck-boost (step-up or step-down, also referred to as fly back), and (d) Cuk converters (Figure 2). The Cuk converter provides the advantage of non-pulsating input-output current ripple requiring smaller size external filters. Output voltage expression is the same as the buck-boost converter and can be less than or greater than the input voltage. There are many variations of the above basic nonisolated converters, and most of them use a high-frequency transformer for ohmic isolation between the input and the output.

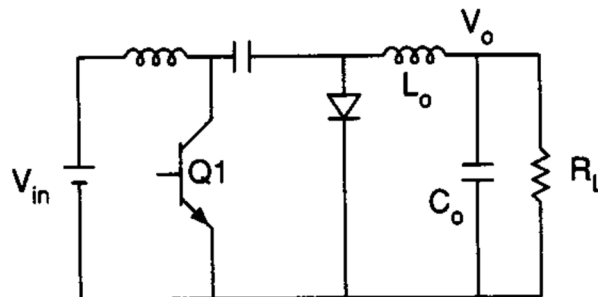

Figure 2: Nonisolated Cuk Converter

### Isolated Single-Ended Topologies

1. The fly back converter (Figure 3) is an isolated version of the buck-boost converter. In this converter (Figure 3), when the transistor is on, energy is stored in the coupled inductor (not a transformer), and this energy is transferred to the load when the switch is off.

Some of the advantages of this converter are that the leakage inductance is in series with the output diode when current is delivered to the output, and, therefore, no filter inductor is required; cross regulation for multiple output converters is good; it is ideally suited for high-voltage output applications; and it has the lowest cost.

Some of the disadvantages are that large output filter capacitors are required to smooth the pulsating output current; inductor size is large since air gaps are to be provided; and due to stability reasons, fly back converters are usually operated in

the DCM, which results in increased losses. To avoid the stability problem, fly back converters are operated with current mode control explained earlier. Fly back converters are used in the power range of 20 to 200 W.

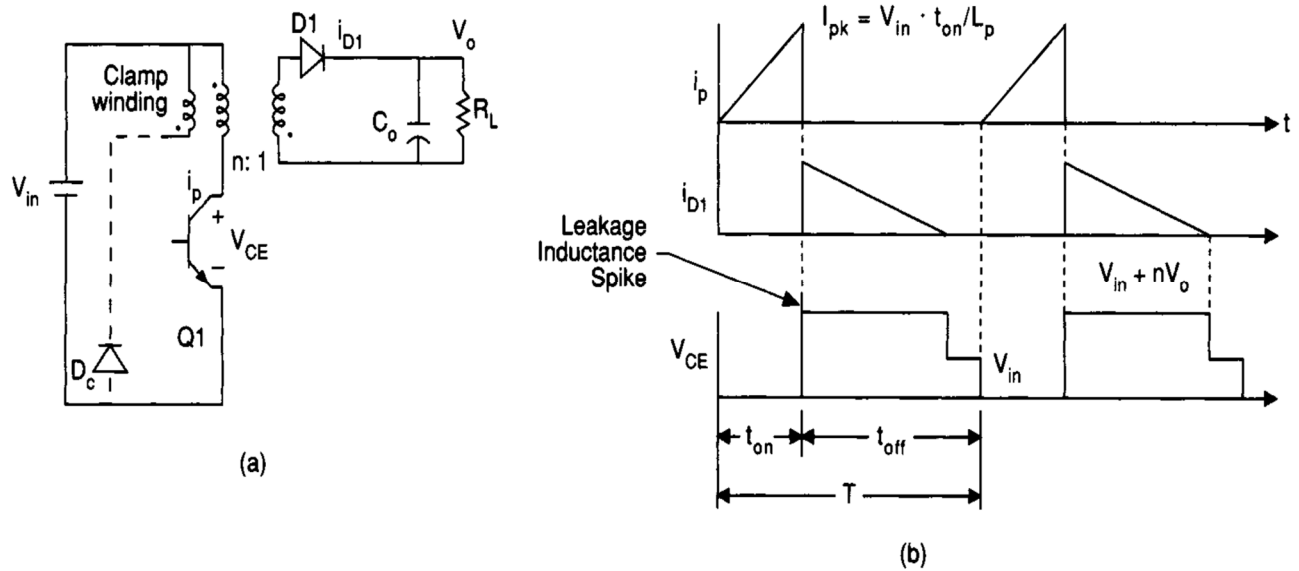

Figure 3:(a) Fly back converter. The clamp winding shown is optimal and is used to clamp the transistor voltage stress to  $V_{in} + nV_o$  (b) Fly back converter waveforms without the clamp winding. The leakage inductance spikes vanish with the clamp winding.

- The forward converter (Figure 4) is based on the buck converter. It is usually operated in the CCM to reduce the peak currents and does not have the stability problem of the fly back converter. The HF transformer transfers energy directly to the output with very small stored energy. The output capacitor size and peak current rating are smaller than they are for the fly back. Reset winding is required to remove the stored energy in the transformer. Maximum duty cycle is about 0.45 and limits the control range. This topology is used for power levels up to about 1 kW.

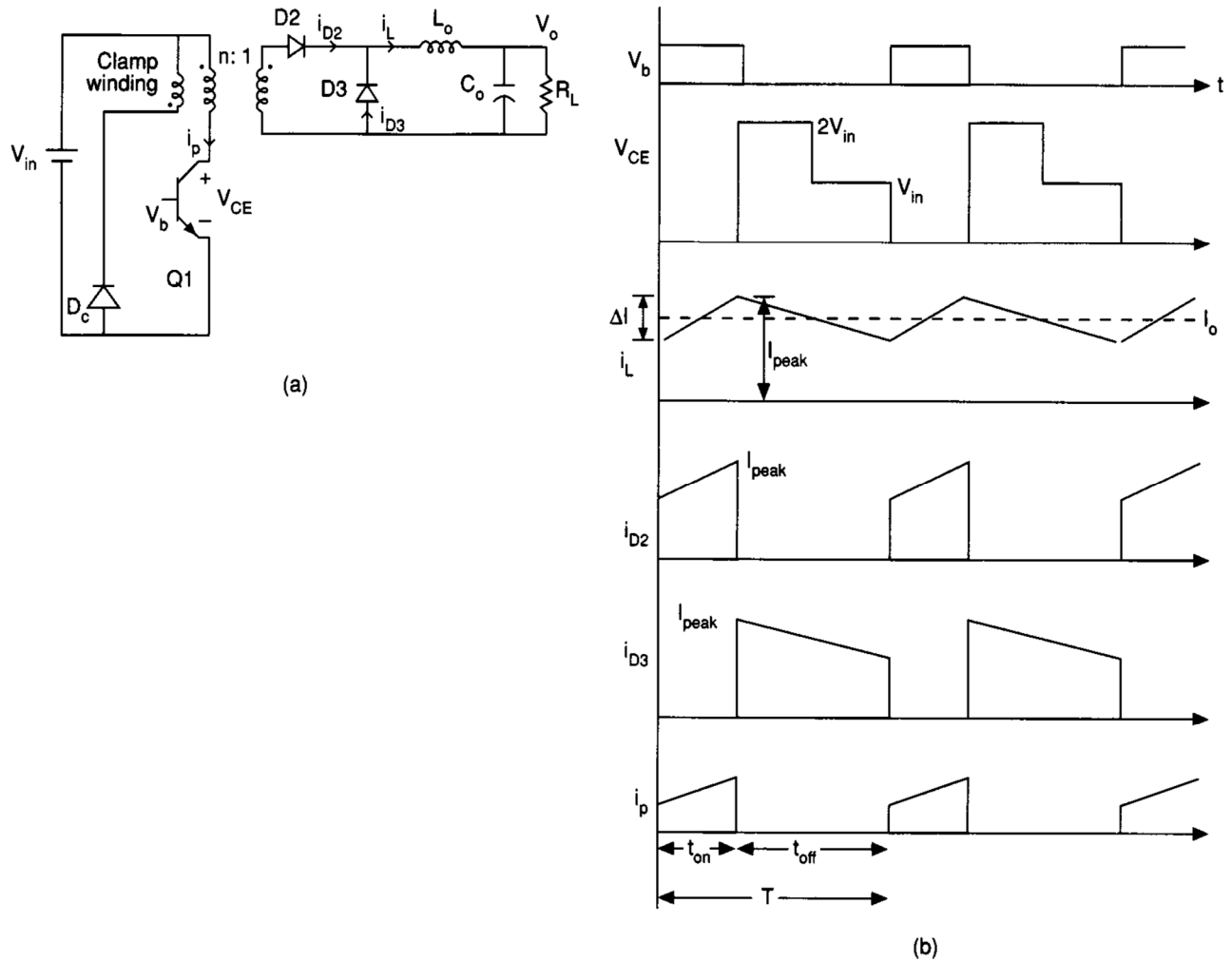

Figure 4:(a) Forward converter. The clamp winding shown is required for operation. (b) Forward converter waveforms.

3. The fly back and forward converters explained above require the rating of power transistors to be much higher than the supply voltage. The two-transistor fly back and forward converters shown in Figure 5 limit the voltage rating of transistors to the supply voltage.
4. The Sepic converter shown in Figure6 is another isolated single-ended PWM converter.

<b>International Association Of Certified Practicing Engineers</b>	<b>ELECTRICAL POWER SUPPLY AND REGULATION</b>	<b>Page 15 of 107</b>
	<b>CPE LEVEL TWO TRAINING MODULE</b>	<b>Rev: 01</b>
		<b>JAN 2016</b>

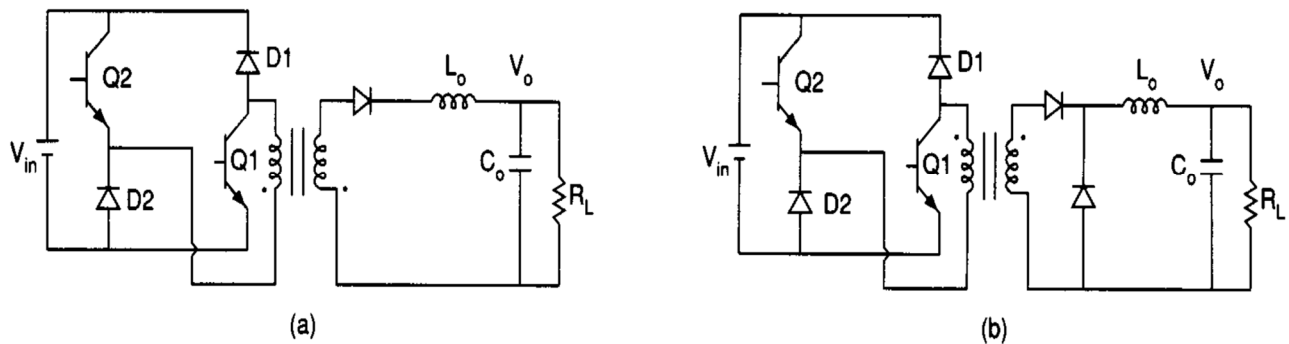

Figure 5:(a) Two – transistor single-ended fly back converter. (b) Two – transistor single – ended forward converter

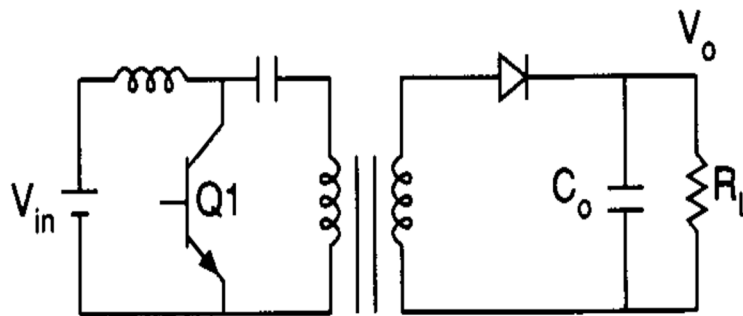
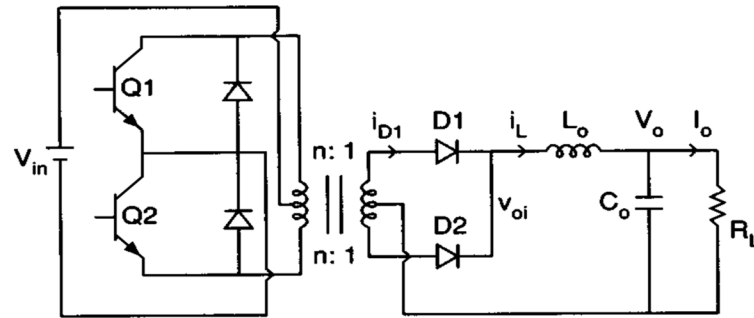

Figure 6: Sepic Converter

### Double-Ended PWM Converters

Usually, for power levels above 300 W, double-ended converters are used. In double – ended converters, full-wave rectifiers are used and the output voltage ripple will have twice the switching frequency. Three important double-ended PWM converter configurations are push-pull (Figure 7), half-bridge (Figure 8), and full-bridge (Figure 9).

1. The push-pull converter. The duty ratio of each transistor in a push-pull converter (Figure 7) is less than 0.5. Some of the advantages are that the transformer flux swings fully, thereby the size of the transformer is much smaller (typically half the size) than single-ended converters, and output ripple is twice the switching frequency of transistors, allowing smaller filters. Some of the disadvantages of this configuration are that transistors must block twice the supply voltage, flux symmetry imbalance can cause transformer saturation and special control circuitry is required to avoid this problem, and use of center-tap transformer requires extra copper resulting in higher volt-ampere (VA) rating. Current mode control (for the primary current) can be used to overcome the flux imbalance. This configuration is used in 100- to 500-W output range.



(a)

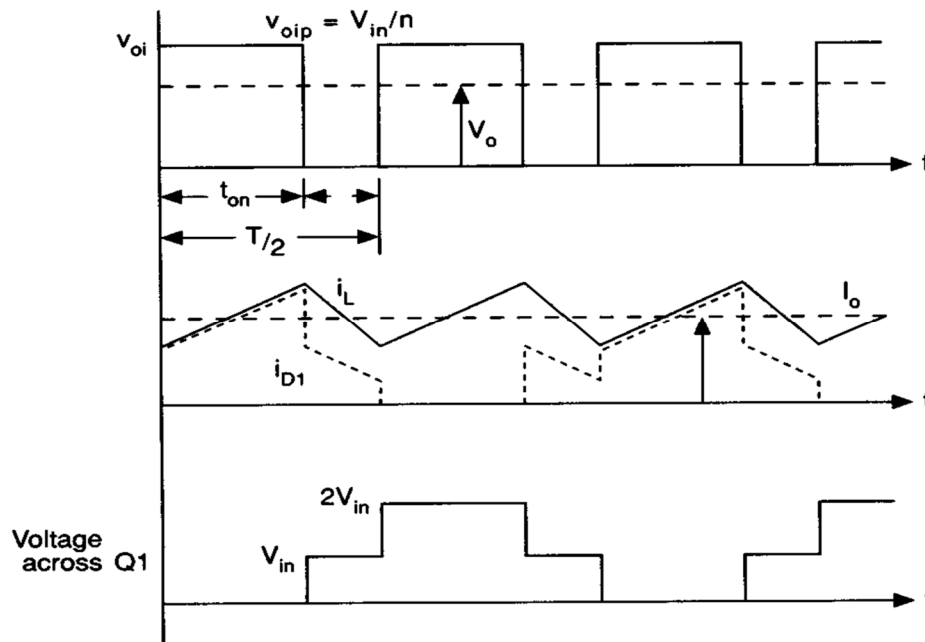

(b)

Figure 7:(a) Push – pull converter and (b) its opening waveforms

2. The half-bridge. In the half-bridge configuration (Figure 8) center-tapped dc source is created by two smoothing capacitors ( $C_{in}$ ), and this configuration utilizes the transformer core efficiently. The voltage across each transistor is equal to the supply voltage (half of push-pull) and, therefore, is suitable for high-voltage inputs. One salient feature of this configuration is that the input filter



<b>International Association Of Certified Practicing Engineers</b>	<b>ELECTRICAL POWER SUPPLY AND REGULATION</b>	<b>Page 17 of 107</b>
	<b>CPE LEVEL TWO TRAINING MODULE</b>	<b>Rev: 01</b>
		<b>JAN 2016</b>

capacitors can be used to change between 110/220-V mains as selectable inputs to the supply. The disadvantage of this configuration is the requirement for large-size input filter capacitors. The half-bridge configuration is used for power levels of the order of 500 to 1000 W.

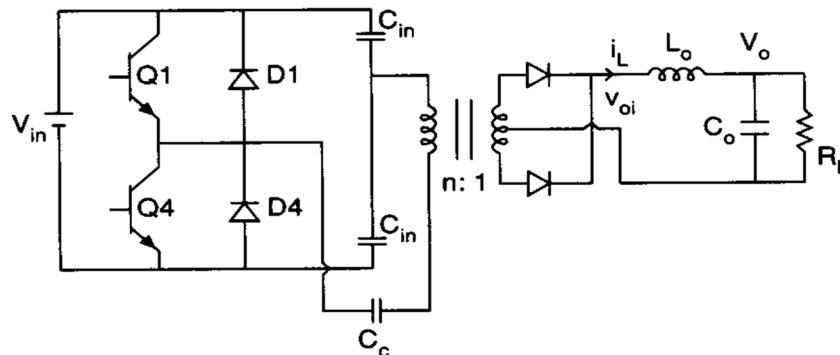

Figure 8:Half – bridge converter. Coupling capacitor  $C_c$ , is used to avoid transformer saturation.

3. The full-bridge configuration (Figure 9) requires only one smoothing capacitor, and for the same transistor type as that of half-bridge, output power can be doubled. It is usually used for power levels above 1 kW, and the design is more costly due to increased number of components (uses four transistors compared to two in push-pull and half-bridge converters). One of the salient features of a full-bridge converter is that by using proper control technique it can be operated in zero-voltage switching (ZVS) mode. This type of operation results in negligible switching losses. However, at reduced load currents, the ZVS property is lost. Recently, there has been a lot of effort to overcome this problem.

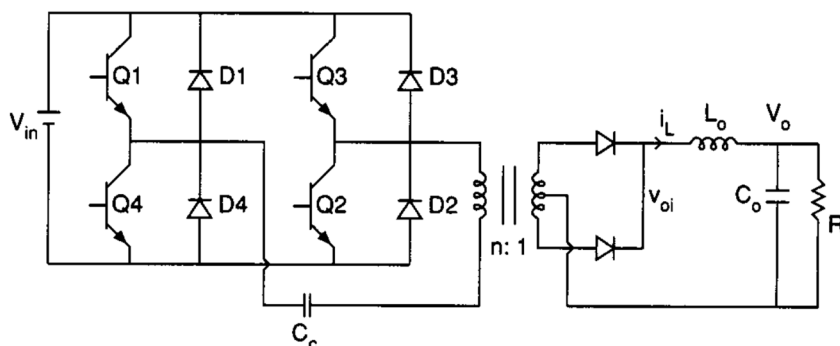

Figure9:Full – Bridge Converter

<b>International Association Of Certified Practicing Engineers</b>	<b>ELECTRICAL POWER SUPPLY AND REGULATION</b>	<b>Page 18 of 107</b>
	<b>CPE LEVEL TWO TRAINING MODULE</b>	<b>Rev: 01</b>
		<b>JAN 2016</b>

## **Resonant Power Supplies**

Similar to the PWM converters, there are two types of resonant converters: single-ended and double-ended. Resonant converter configurations are obtained from the PWM converters explained earlier by adding LC (inductor-capacitor) resonating elements to obtain sinusoidally varying voltage and/or current waveforms. This approach reduces the switching losses and the switch stresses during switching instants, enabling the converter to operate at high switching frequencies, resulting in reduced size, weight, and cost. Some other advantages of resonant converters are that leakage inductances of HF transformers and the junction capacitances of semiconductors can be used profitably in the resonant circuit, and reduced EMI. The major disadvantage of resonant converters is increased peak current (or voltage) stress.

### **Single-Ended Resonant Converters**

They are referred to as quasi-resonant converters (QRCs) since the voltage(or current) waveforms are quasi-sinusoidal in nature. The QRCs can operate with zero-current switching (ZCS) or ZVS or both. All the QRC configurations can be generated by replacing the conventional switches by the resonant switches shown in Figures 10 and 11. A number of configurations are realizable. Basic principles of ZCS and ZVS are explained briefly below.

1. Zero-current switching QRCs. Figure 12(a) shows an example of aZCS QR buck converter implemented using a ZC resonant switch. Depending on whether the resonant switch is half-wave type or full-wave type, the resonating current will be only half-wave sinusoidal (Figure 12 (b)) or a full sine-wave (Figure 12 (c)). The device currents are shaped sinusoidally, and, therefore, the switching losses are almost negligible with low turn-on and turn-off stresses. ZCS QRCscan operate at frequencies of the order of 2 MHz. The major problems with this type of converter are high peak currents through the switch and capacitive turn-on losses.

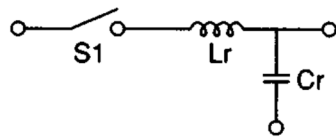

(a)(i)

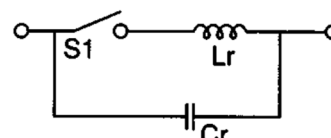

(a)(ii)

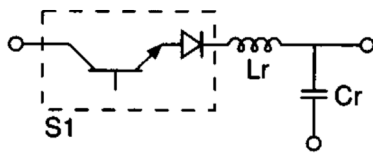

(b)

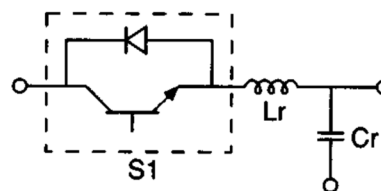

(c)

Figure 10:(a) Zero – current resonant switch: (i) L – type and (ii) M – Type. (b) Half wave configuration using L – Type ZC resonant switch. (c) Full – wave configuration using L – Type ZC resonant switch

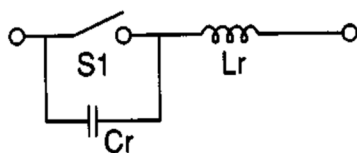

(a)(i)

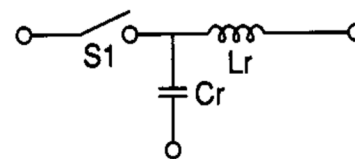

(a)(ii)

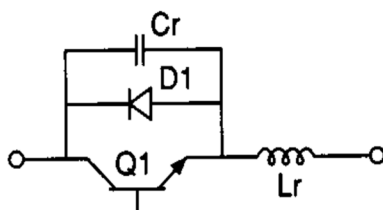

(b)

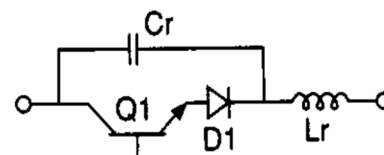

(c)

Figure11:(a) Zero – voltage resonant switches. (b) Half – wave configuration using ZV resonant switch shown in Figure 10. (a)(i). (c) Full – wave configuration using ZV resonant switch shown in Figure (a)(i).

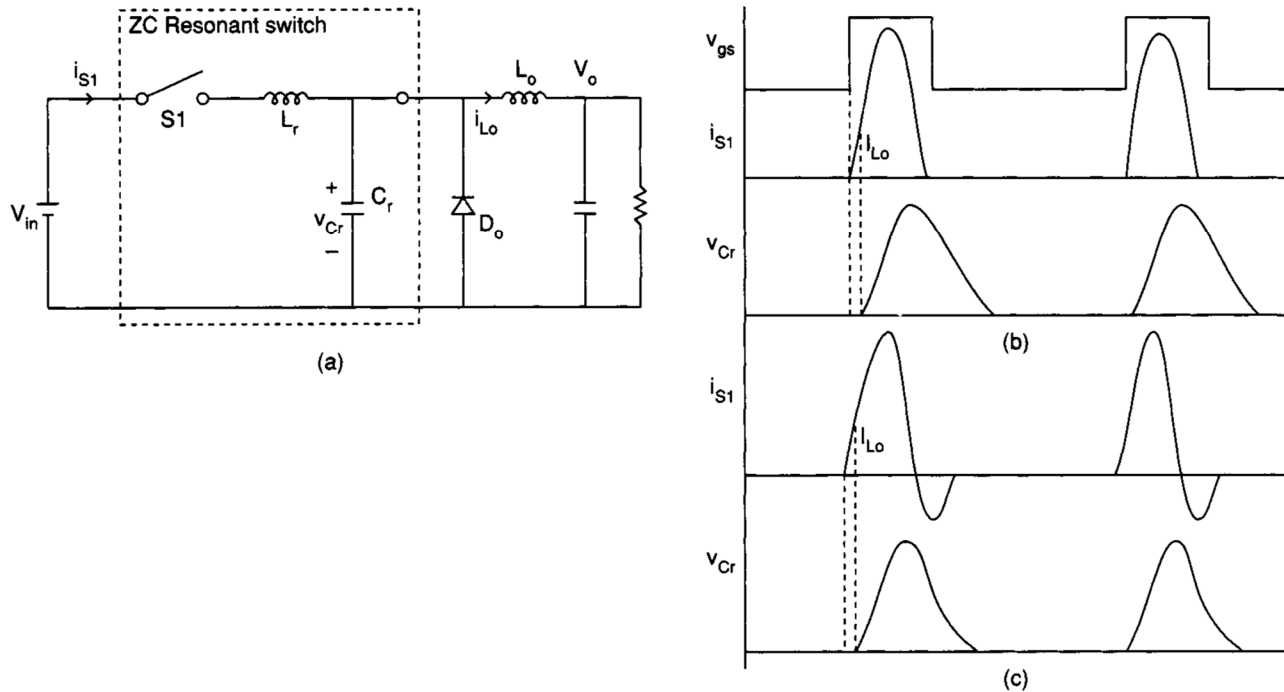

Figure 12: (a) Implementation of ZCS QR buck converter using L – Type resonant switch. (b) Operating waveforms for half – wave mode. (c) Operating waveforms for full – wave mode.

2. Zero-voltage switching QRCs. ZVS QRCs are duals of ZCS QRCs. The auxiliary LC elements are used to shape the switching device's voltage waveform at off time in order to create a zero-voltage condition for the device to turn on Figure 13(a) shows an example of ZVS QRboost converter implemented using a ZV resonant switch. The circuit can operate in the half-wave mode (Figure 13(b)) or in the full-wave mode (Figure 13(c)) depending on whether a half-wave or full-wave ZV resonant switch is used, and the name comes from the capacitor voltage waveform. The full-wave mode ZVS circuit suffers from capacitive turn-on losses. The ZVS QRCs suffer from increased voltage stress on the switch. However, they can be operated at much higher frequencies compared to ZCS QRCs.

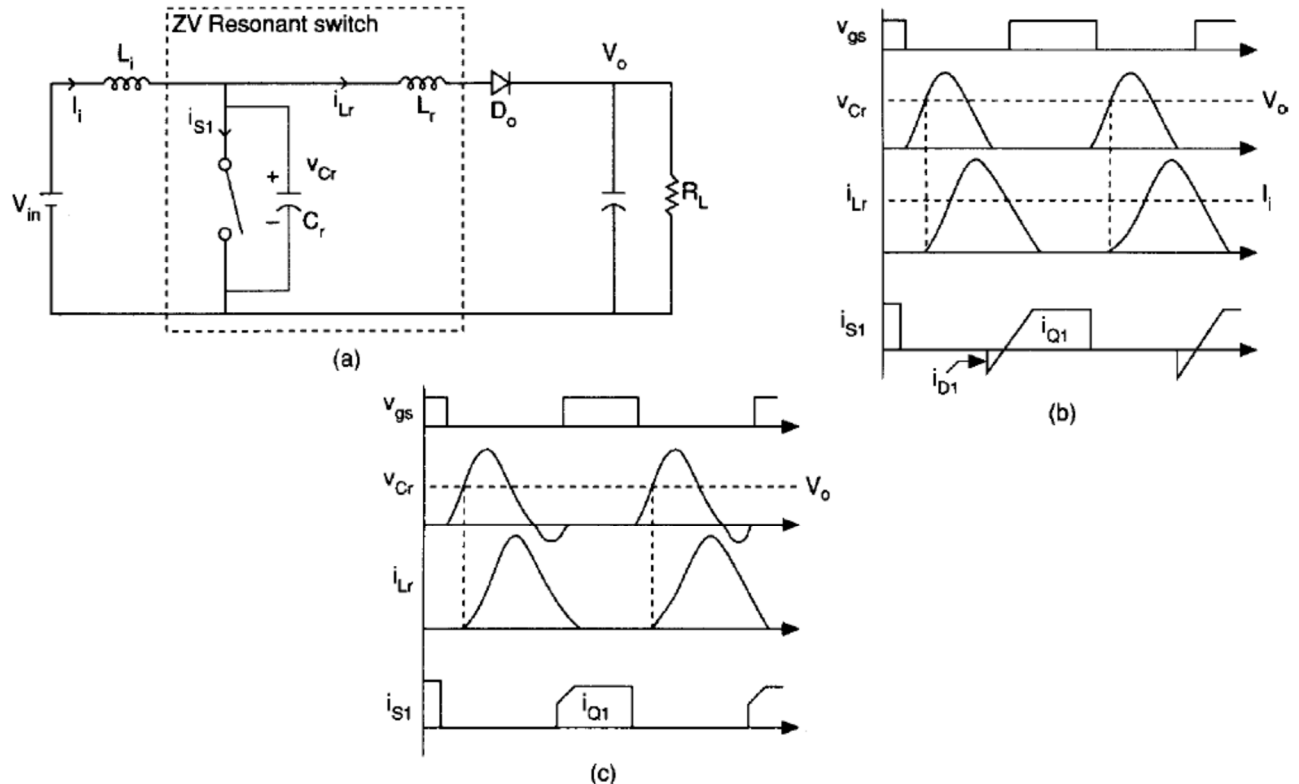

Figure 13: (a) Implementation of ZV QR boost converter using resonant switch shown in Figure 12 (a) (i). (b) Opening waveforms for half-wave mode. (c) Operating waveforms for full-wave mode.

## Double-Ended Resonant Converters

These converters use full-wave rectifiers at the output, and they are generally referred to as resonant converters. A number of resonant converter configurations are realizable by using different resonant tank circuits, and the three most popular configurations, namely, the series resonant converter (SRC), the parallel resonant converter (PRC), and the series-parallel resonant converter (SPRC) (also called LCC-type PRC), are shown in Figure 13. Series resonant converters (Figure 14. (a)) have high efficiency from full load to part load. Transformer saturation is avoided due to the series blocking resonating capacitor. The major problems with the SRC are that it requires a very wide change in switching frequency to regulate the load voltage and the output filter capacitor must carry high ripple current (a major problem especially in low output voltage, high output current applications).

Parallel resonant converters (Figure 14(b)) are suitable for low output voltage, high output current applications due to the use of filter inductance at the output with low ripple current requirements for the filter capacitor. The major disadvantage of the PRC is that the device currents do not decrease with the load current, resulting in reduced efficiency at reduced load currents.

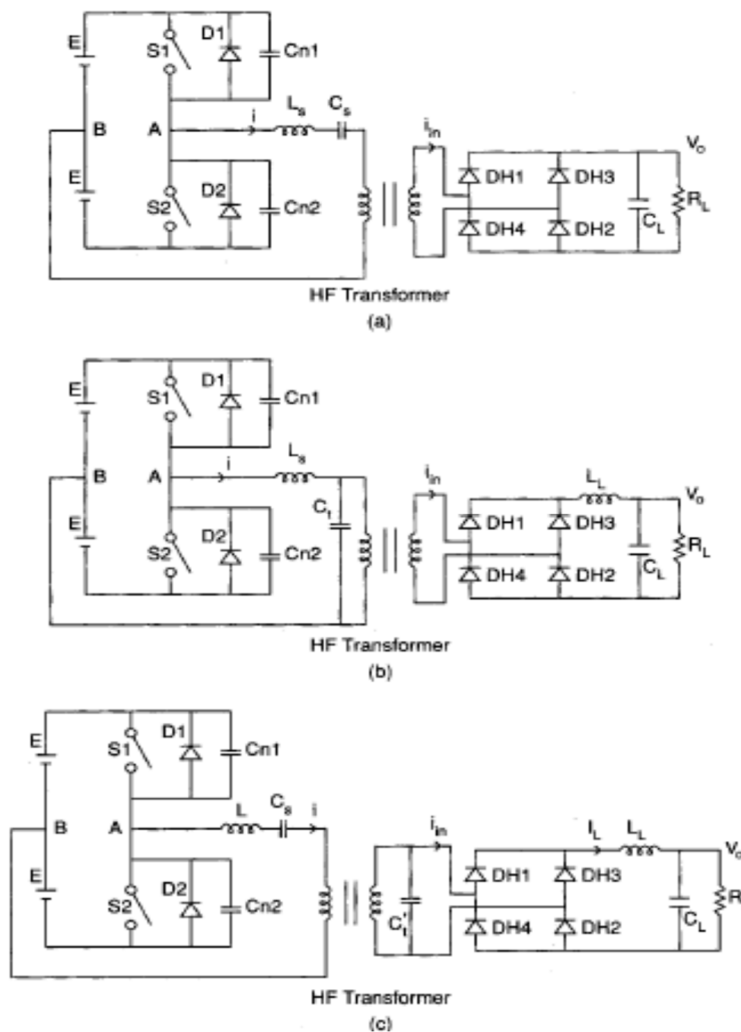

Figure 14: High-frequency resonant converter (half-bridge version) configurations suitable for operation above resonance. Cn1 and Cn2 are the snubber capacitors. (a) Series resonant converter. Leakage inductances of the HF transformer can be part of resonant inductance. (b) Parallel resonant converter. (c) Series-parallel (or LCC-type) resonant converter with capacitor Ct placed on the secondary side of the HF transformer.

<b>International Association Of Certified Practicing Engineers</b>	<b>ELECTRICAL POWER SUPPLY AND REGULATION</b>	<b>Page 23 of 107</b>
		<b>Rev: 01</b>
		<b>JAN 2016</b>
<b>CPE LEVEL TWO TRAINING MODULE</b>		

## Definition

Current	: The density of the atoms in copper wire is such that the valence orbits of the individual atoms overlap.
Current Limiting	: A technique used to provide short-circuit protection. Typically, current sensing resistor is used to turn a transistor on and off that in turn is used to provide negative feedback to hold the output current at a high but safe value.
Dropout Voltage	: The input – output voltage differential at which the circuit ceases to regulate against further reductions in input voltage.
Diode	: A semiconductor device made up of a P and n type semiconductor type.
Filter Circuit	: The circuit used to filter out AC ripple from DC.
Fly back Regulator	: The technique by which the regulated load power is transferred during the off time of the switching device.
Fold back Current Limiting	: A more sophisticated type of short – circuit protection in which the output current is cut dramatically back, not just held constant.
Forward Regulator	: The technique by which the regulated load power is transferred during the on time of the switching device.
Inductance	: The property which opposes any change in the existing current. Inductance is present only when the current is changing.
Line Regulation	: The percent change of output voltage for a change in input supply voltage.
Linear Regulator	: Voltage regulator using a transistor operating in the linear region.

<b>International Association Of Certified Practicing Engineers</b>	<b>ELECTRICAL POWER SUPPLY AND REGULATION</b>	<b>Page 24 of 107</b>
		<b>Rev: 01</b>
		<b>JAN 2016</b>
<b>CPE LEVEL TWO TRAINING MODULE</b>		

- Load Regulation** : The percent change of output voltage for a change in output current.
- Low dropout voltage** : Refers to a class of voltage regulators designed to operate at especially low input-output voltage differentials.
- Magneto motive Force (mmf)** : The product of the current and the number of turns in the transformer.
- Rectifier** : A device that converts AC signals to DC.
- Regulator** : An electronic device that attempts to keep the output signal constant in spite of changes in the other system characteristics.
- Resistor** : Made of materials that conduct electricity, but offer opposition to current flow.
- Ripple** : The fluctuation on the DC input signal to the voltage regulator, caused by the charging and discharging of the capacitor input filter.
- Ripple Rejection** : A measure of how well the regulator attenuates the input ripple, usually specified in decibels.
- Ripple Voltage** : The AC voltage associated with the DC in a rectifier circuit.
- Switching Regulator** : A voltage that operates by using a saturating switching transistor to chop an unregulated DC voltage. This chopped voltage is then filtered. The duty cycle of the switching transistor is varied to provide regulation of the output voltage.
- Topology** : The overall design technique, or layout, by which an electronic device, such as a switching power supply regulator, operates.



<b>International Association Of Certified Practicing Engineers</b>	<b>ELECTRICAL POWER SUPPLY AND REGULATION</b>	<b>Page 25 of 107</b>
		<b>Rev: 01</b>
	<b>CPE LEVEL TWO TRAINING MODULE</b>	<b>JAN 2016</b>

Transformers : A device used to step up or step down the AC voltage and to isolate mains supply from the rectifier circuit.

Voltage : The basic unit of measure for potential difference is the volt (symbol V), and because the volt unit is used, potential difference is called voltage.

Voltage regulator : That part of a power supply that accepts a filtered DC voltage and reduces, if not eliminates, the ripple, providing a continuous, smooth DC signal.

### **Nomenclature**

A : Cross-sectional Area  
 $A_L$  : Inductance index in milli  
D : Diodes  
i : Current  
 $I_{load}$  : Load DC Current  
L : winding inductance  
N : Number of turns in the coil  
R : Resistance  
 $R_p$  : Primary windings resistance  
 $R_s$  : Secondary windings resistance  
 $R_{se}$  : Equivalent resistance in the secondary circuit  
 $\mu$  : Permeance of the core material  
t : Time  
v : Voltage  
 $r_D$  : diode resistance  
 $V_{Do}$  : diode forward voltage  
 $V_{DC}$  : DC output voltage from the filter  
 $V_i$  : the input voltage  
 $V_{load}$  : load DC Voltage  
 $X_m$  : Magnetizing resistance  
 $X_p$  : Primary windings leakage resistance  
 $X_s$  : Secondary winding leakage resistance  
 $X_{se}$  : Equivalent leakage resistance in the secondary circuit  
W : Energy  
Z : Impedance

<b>International Association Of Certified Practicing Engineers</b>	<b>ELECTRICAL POWER SUPPLY AND REGULATION</b>  <b>CPE LEVEL TWO TRAINING MODULE</b>	<b>Page 26 of 107</b>
		<b>Rev: 01</b>
		<b>JAN 2016</b>

### **Greek Letters**

$\alpha_{Ti}$  : Temperature coefficient

$\mu$  : Permeability

$\phi$  : Magnetic Flux

$\theta$  : Angle